

SCM SERIES

CENTRIFUGAL PUMPS

SCM series are single stage centrifugal pumps, suitable for both domestic and industrial applications to convey clean liquids and non-aggressive chemical fluids.

PERFORMANCE AND WORKING LIMITS

Protection: IP 44
 Insulation class F
 Max. Pressure 10bar
 Max. Suction lift up to 8m
 Fluid temperature up to +80°C
 Max. ambient temperature up to +40°C

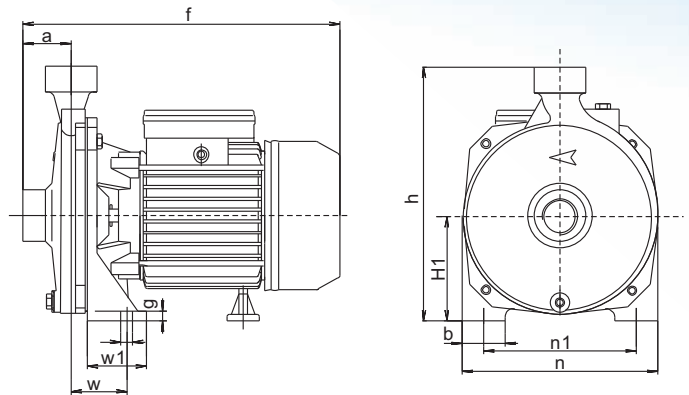
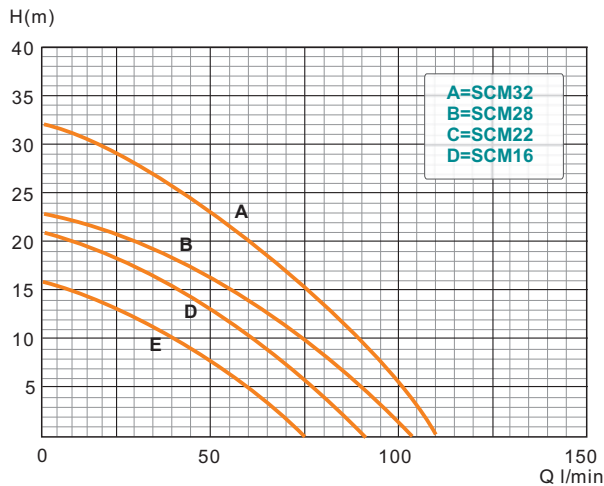

OVERALL AND MOUNTING DIMENSION

TYPE	Dimensions mm										
	a	f	h	H1	c	w	W1	n1	n	g	s
SCM16	45	280	200	85	158	45	40	110	40	9	10
SCM22	51	286	205	85	162	47	40	110	40	9	10
SCM28	45	297	226	97	182	53	55	142	40	9	11
SCM32	45	297	237	97	182	53	55	142	40	9	11

TECHNICAL DATA

TYPE	Input Power		Current (A)	Capacitor (F)	H.max (m)	Q.max (L/min)	Size (inch)	S.Head (m)	Packing QTY.	L×W×H (mm)	N.W (kg)
	kW	HP									
SCM16	0.37	0.5	1.6	8	16	75	1"X1"	8	2500	280x157x205	8
SCM22	0.5	0.75	2.5	12	21	90	1"X1"	8	2300	280X157X210	8.8
SCM28	0.75	1	3.8	16	23	105	1"X1"	8	2000	300X170X205	10
SCM32	1	1.5	4.8	20	32	110	1"X1"	8	1800	300x180x240	14.1